

EDI – Ideal Message CH IFTSTA



Overview

Document information	
Title	Ideal Message IFTSTA - Vers. 4.1.0
Last modification	December 2022
Version	4.1.0 Based on EANCOM * 2002
Publication	December 2022
Publisher	GS1 Switzerland
Image source	iStock

Disclaimer

While GS1 and all other parties involved in producing this document have made every effort to ensure the accuracy of the GS1 System standards, we state that this document is made available with no express or implied warranty for any damage or loss resulting from the use of this document. The document is in line with the state of the art and is periodically revised due to technological developments, changes to standards and new legal circumstances. Some of the products and company names mentioned in this document may be trademarks and/or registered trademarks of the relevant companies. GS1 is a registered trademark of GS1 AISBL in Brussels, Belgium.

Ideal-Message Switzerland

IFTSTA 4.1.0

Documentation conventions

Format and pictures

as described in column "Format" of segment details

Character type:

a :alphabetic characters
n :numeric characters
an :alpha-numeric characters

Size:

Fixed : all positions must be used
Variable : positions may be used up to a specified maximum

Examples:

as described in column "St" of segment details

Status indicators

as described in column "St" of segment details

(R)equired

Indicates that the entity is required and must be sent. (This status is set by EANCOM®.)

(C)onditional

Indicates that the entity is conditional and may be sent at the discretion of the user.

(D)ependent

Indicates that the entity must be sent in certain conditions, as defined by the relevant explanatory note.

(N)ot used

Indicates that the entity is not used.

Restriction indicators

as described in column "R" of segment details

Restricted (*)

A data element marked with an asterisk (*) in the fourth column of the segment details of a message indicates that the listed codes in column five are the only codes available for use with the data element at the same level as the asterisk, in the current segment, in the current message.

Open

All data elements in which coded representation of data is possible, and in which a restricted set of code values is not indicated, are open. The available codes are listed in the Data Elements and Code Sets Directory (Part III of this manual). Code values may be given as examples or there may be a note on the format or type of code to be used.

Ideal-Message Switzerland

IFTSTA 4.1.0

Branching diagram

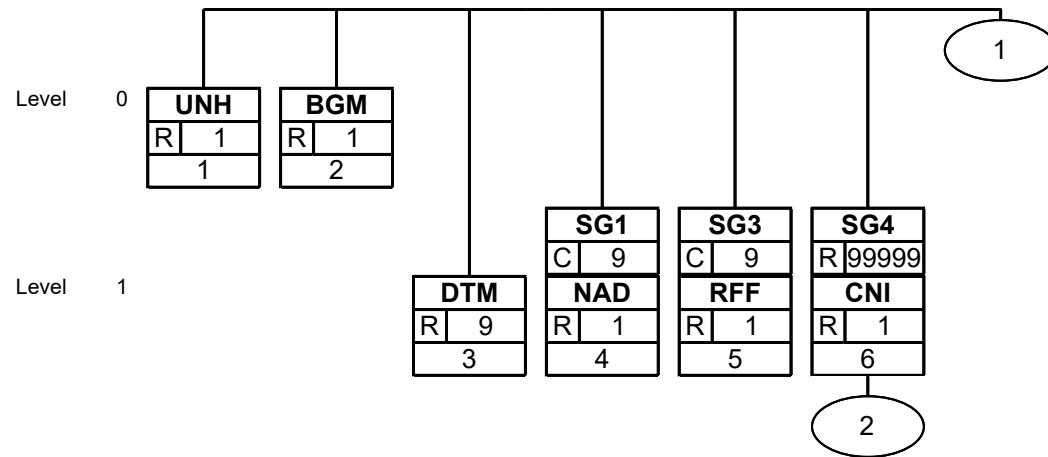

Ideal-Message Switzerland

IFTSTA 4.1.0

Branching diagram

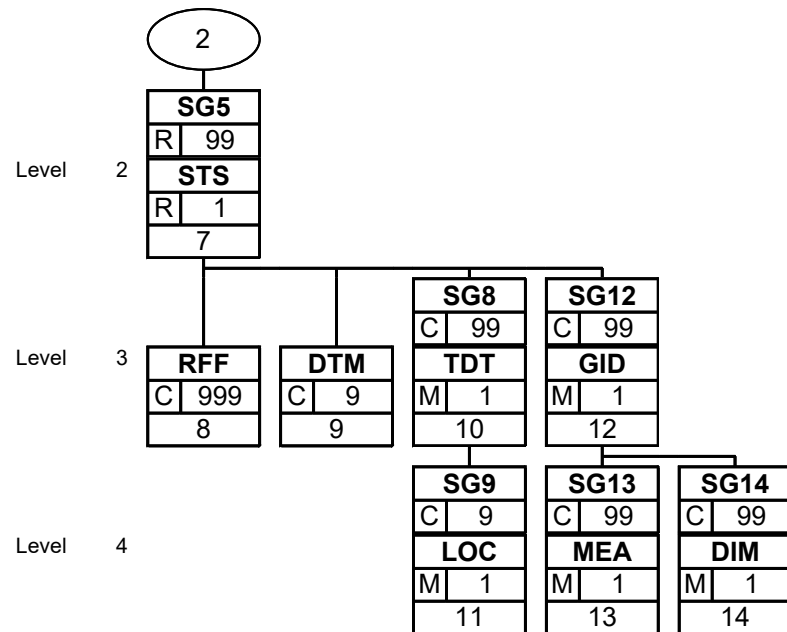

Ideal-Message Switzerland

IFTSTA 4.1.0

Branching diagram

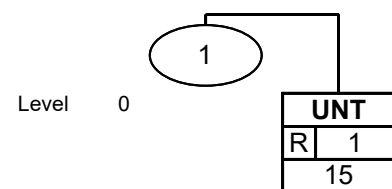

Ideal Message Switzerland

IFTSTA 4.1.0

Segments Layout

Segment **UNH** No.: 1 Level: 0 Message header
 Status: R Max. occ.: 1

Description Message header

Description of Segment:

	Description	St Format	*	Example	Remarks
0062	Message reference number	R an..14		+ME000001	Senders unique message reference. Sequence number of the messages in the interchange. DE 0062 in the UNT will be identical. Sender generated.
S009	Message identifier	R			
0065	Message type	R an..6	*	+IFTSTA	IFTSTA = International multimodal status report message
0052	Message version number	R an..3	*	:D	D = Draft version/UN/EDIFACT Directory
0054	Message release number	R an..3	*	:01B	01B = Release 2001 - B
0051	Controlling agency	R an..2	*	:UN	UN = UN/CEFACT
0057	Association assigned code	R an..6	*	:EAN004'	EAN004 = GS1 version control number (GS1 Permanent Code)

Description:

This segment is used to head, identify and specify a message.

DE's 0065, 0052, 0054, and 0051: Indicate that the message is a UNSM Transport Status message based on the D.01B directory under the control of the United Nations.

Example:

UNH+ME000001+IFTSTA:D:01B:UN:EAN004'

Ideal Message Switzerland

IFTSTA 4.1.0

Segments Layout

Segment

BGM

No.: 2
Status: R

Level: 0
Max. occ.: 1

Beginning of message

Description Beginning of message

Description of Segment:

	Description	St Format	*	Example	Remarks
C002	Document/message name	R			
1001	Document name code	R an..3	*	+44	44 = Transport status report
C106	Document/message identification	R			
1004	Document identifier	R an..35		+569952	Transport status number assigned by the document sender.
1225	Message function code	R an..3	*	+9'	9 = Original

Description:

This segment is used to indicate the type and function of a message and to transmit the identifying number.

All references other than the document number DE 1004 are to be put in the RFF segment.

Example:

BGM+44+569952+9'

Ideal Message Switzerland

IFTSTA 4.1.0

Segments Layout

Segment **DTM** No.: 3 Level: 1 Date/time/period
Status: R Max. occ.: 9

Description **Date/time/period**

Description of Segment:

	Description	St Format	*	Example	Remarks
C507	Date/time/period	R			
2005	Date or time or period function code qualifier	R an..3	*	+137	35 = Delivery date/time, actual 76 = Delivery date/time, scheduled for 137 = Document/message date/time
2380	Date or time or period value	R an..35		: 2015041 013205	
2379	Date or time or period format code	R an..3	*	:204'	204 = CCYYMMDDHHMMSS

Description:

This segment is used to specify the date of the transport status message.

DE 2005: Identification of the 'Document/message date/time' (code value 137) is mandatory in an EANCOM message.

Example:

DTM+137:2015041013205:204'

Ideal Message Switzerland

IFTSTA 4.1.0

Segments Layout

Group **SG1** Status:C Max. occ.: 9 NAD

Segment **NAD** No.: 4 Level: 1 Name and address
Status:R Max. occ.: 1

Description Name and address

Description of Segment:

	Description	St Format	*	Example	Remarks
3035	Party function code qualifier	R an..3	*	+FW	BY = Buyer FW = Freight forwarder UC = Ultimate consignee SU = Supplier
C082	Party identification details	A			
3039	Party identifier	R an..35		+761234 5000018	
1131	Code list identification code	N an..17		:	
3055	Code list responsible agency code	R an..3	*	:9	9 = GS1
C058	Name and address	N			
3124	Name and address description	N an..35		+	
C080	Party name	D			
3036	Party name	R an..35		+Frau Anna Müller	Party Name in clear text.
3036	Party name	C an..35		:X	
C059	Street	D			
3042	Street and number or post office box identifier	R an..35		+Kramg asse 17	Building Name/Number and Street
3042	Street and number or post office box identifier	C an..35		:3. Stock	Name and/or P.O. Box
3164	City name	D an..35		+Huttwil	City/Town, clear text.
C819	Country sub-entity details	C			
3229	Country sub-entity name code	C an..9		+	
3251	Postal identification code	D an..17		+4950	Postal Code
3207	Country name code	D an..3		+CH'	ISO 3166 two alpha code

Description:

This segment is used to identify the trading partners involved in the Transport Instruction message. Identification of the Consignor and Carrier or Forwarder is mandatory in the Transport Instruction message. If required, a Consignee may also be identified using NAD at this level in the message.

Dependency Notes:

Ideal Message Switzerland

IFTSTA 4.1.0

Segments Layout

The following composites and data elements are only used when a coded name and address can not be used. The affected composites and data elements are as follows:

C080 - C059 - 3164 - C819 - 3251 - 3207

Example:

NAD+FW+5412345000013::9'

NAD+UC+++Frau Anna Müller+Kramgasse 17:3. Stock+Huttwil++4950+CH'

Ideal Message Switzerland

IFTSTA 4.1.0

Segments Layout

<i>Group</i>	SG3	Status:C	Max. occ.: 9	RFF
<i>Segment</i>	RFF	No.: 5 Status:R	Level: 1 Max. occ.: 1	Reference

Description Reference

Description of Segment:

	Description	St Format	*	Example	Remarks
C506	Reference	R			
1153	Reference code qualifier	R an..3	*	+ON	AAS = Transport document number AWB = Air waybill number BM = Bill of lading number FF = Freight forwarder's reference number HWB = House waybill number IV = Invoice number ON = Order number (buyer) MWB = Master air waybill number
1154	Reference identifier	R an..70		:76214'	

Description:

This segment is used to specify references relating to a previously sent transport instruction for which a status is being requested or provided.

Example:

RFF+ON:76214'

Ideal Message Switzerland

IFTSTA 4.1.0

Segments Layout

Group **SG4** Status:R Max. occ.: 99999 CNI-SG5

Segment **CNI** No.: 6 Level: 1 Consignment information
Status:R Max. occ.: 1

Description Consignment information

Description of Segment:

	Description	St Format	*	Example	Remarks
1490	Consolidation item number	R n..4		+1	
C503	Document/message details	C			
1004	Document identifier	R an..35		+123445 ,	

Description:

This segment is used to identify a consignment for which status information is being provided. In the IFTMnn messages the consignor's shipment reference number is provided in data element 1153 of the RFF segment at the message level using the code value 'CU'.

Example:

CNI+12+AVV23441'

Ideal Message Switzerland

IFTSTA 4.1.0

Segments Layout

Group	SG4	Status:R	Max. occ.: 99999	CNI-SG5
Group	SG5	Status:R	Max. occ.: 99	STS-RFF-DTM-SG8-SG12
Segment	STS	No.: 7 Status:R	Level: 2 Max. occ.: 1	Status

Description Status

Description of Segment:

	Description	St Format	*	Example	Remarks
C601	Status category	N			
9015	Status category code	N an..3		+1	
C555	Status	R			
4405	Status description code	M an..3		+1E	Open code list
1131	Code list identification code	C an..17		:23	
3055	Code list responsible agency code	D an..3	*	:9	9 = GS1 92 = Assigned by buyer or buyer's agent
C556	Status reason	C			
9013	Status reason description code	M an..3		+13	Open code list
1131	Code list identification code	C an..17		:23	
3055	Code list responsible agency code	D an..3	*	:9'	9 = GS1 92 = Assigned by buyer or buyer's agent

Description:

This segment is used to request or provide status information regarding the currently referenced consignment.

The consignment has not been collected because payment for the transport has not yet been received.

The consignment has been delivered.

Dependency Notes:

DE 3055: This data element is only used when GS1 code values are being used in data element 9015, 4405 or 9013.

Example:

STS++76E::9+46'

STS++21'

Ideal Message Switzerland

IFTSTA 4.1.0

Segments Layout

Group	SG4	Status:R	Max. occ.: 99999	CNI-SG5
Group	SG5	Status:R	Max. occ.: 99	STS-RFF-DTM-SG8-SG12
Segment	RFF	No.: 8 Status:C	Level: 3 Max. occ.: 999	Reference

Description Reference

Description of Segment:

	Description	St Format	*	Example	Remarks
C506	Reference	M			
1153	Reference code qualifier	R an..3	*	+DQ	DQ = Delivery note number ON = Order number (buyer)
1154	Reference identifier	R an..70		:6532'	

Description:

This segment is used to identify any reference associated with the status information in the STS segment.

Example:

RFF+DQ:6532'

Ideal Message Switzerland

IFTSTA 4.1.0

Segments Layout

Group	SG4	Status:R	Max. occ.: 99999	CNI-SG5
Group	SG5	Status:R	Max. occ.: 99	STS-RFF-DTM-SG8-SG12
Segment	DTM	No.: 9 Status:C	Level: 3 Max. occ.: 9	Date/time/period

Description Date/time/period

Description of Segment:

	Description	St Format	*	Example	Remarks
C507	Date/time/period	R			
2005	Date or time or period function code qualifier	R an..3	*	+334	132 334 = Arrival date/time, estimated = Status change date/time
2380	Date or time or period value	R an..35		: 2015041 4000000	
2379	Date or time or period format code	R an..3	*	:204'	204 = CCYYMMDDHHMMSS

Description:

This segment is used to specify any dates associated with the consignment for which status information is being requested or provided.

Example:

DTM+171:20020615:102'

Ideal Message Switzerland

IFTSTA 4.1.0

Segments Layout

Group	SG4	Status:R	Max. occ.: 99999	CNI-SG5
Group	SG5	Status:R	Max. occ.: 99	STS-RFF-DTM-SG8-SG12
Group	SG8	Status:C	Max. occ.: 99	TDT-SG9
Segment	TDT	No.: 10 Status:M	Level: 3 Max. occ.: 1	Details of transport

Description Details of transport

Description of Segment:

	Description	St Format	*	Example	Remarks
8051	Transport stage code qualifier	M an..3		+20	open code list
8028	Means of transport journey identifier	C an..17		+	
C220	Mode of transport	C			
8067	Transport mode name code	C an..3		+30	Open code list
C228	Transport means	C			
8179	Transport means description code	C an..8		+31	
C040	Carrier	C			
3127	Carrier identifier	N an..17		+X	
1131	Code list identification code	N an..17		:	
3055	Code list responsible agency code	N an..3		:	
3128	Carrier name	C an..35		:Camion AG'	

Description:

Example:

Ideal Message Switzerland

IFTSTA 4.1.0

Segments Layout

Group	SG4	Status:R	Max. occ.: 99999	CNI-SG5
Group	SG5	Status:R	Max. occ.: 99	STS-RFF-DTM-SG8-SG12
Group	SG8	Status:C	Max. occ.: 99	TDT-SG9
Group	SG9	Status:C	Max. occ.: 9	LOC
Segment	LOC	No.: 11 Status:M	Level: 4 Max. occ.: 1	Place/location identification

Description Place/location identification

Description of Segment:

	Description	St Format	*	Example	Remarks
3227	Location function code qualifier	M an..3	*	+1	5 = Place of departure 27 = Country of origin 35 = Country of exportation/despatch
C517	Location identification	C			
3225	Location name code	C an..25		+THHK G	
1131	Code list identification code	C an..17		:	
3055	Code list responsible agency code	C an..3		:6'	3 = IATA (International Air Transport Association) 6 = UN/ECE (United Nations - Economic Commission for Europe) 9 = GS1

Description:

Example:

Ideal Message Switzerland

IFTSTA 4.1.0

Segments Layout

Group	SG4	Status:R	Max. occ.: 99999	CNI-SG5
Group	SG5	Status:R	Max. occ.: 99	STS-RFF-DTM-SG8-SG12
Group	SG12	Status:C	Max. occ.: 99	GID-SG13-SG14
Segment	GID	No.: 12 Status:M	Level: 3 Max. occ.: 1	Goods item details

Description Goods item details

Description of Segment:

	Description	St Format	*	Example	Remarks
1496	Goods item number	C n..5		+1	
C213	Number and type of packages	C			
7224	Package quantity	C n..8		+200	
7065	Package type description code	C an..17		:08	Open code list
C213	Number and type of packages	C			
7224	Package quantity	C n..8		+4500	
7065	Package type description code	C an..17		:08'	Open code list

Description:

Example:

Ideal Message Switzerland

IFTSTA 4.1.0

Segments Layout

Group	SG4	Status:R	Max. occ.: 99999	CNI-SG5
Group	SG5	Status:R	Max. occ.: 99	STS-RFF-DTM-SG8-SG12
Group	SG12	Status:C	Max. occ.: 99	GID-SG13-SG14
Group	SG13	Status:C	Max. occ.: 99	MEA
Segment	MEA	No.: 13 Status:M	Level: 4 Max. occ.: 1	Measurements

Description Measurements

Description of Segment:

	Description	St Format	*	Example	Remarks
6311	Measurement purpose code qualifier	M an..3	*	+PD	PD = Physical dimensions (product ordered) VOL = WT =
C502	Measurement details	C			
6313	Measured attribute code	C an..3	*	+AAD	AAD = Total gross weight ABJ = Volume AAW = Gross volume
C174	Value/range	C			
6411	Measurement unit code	M an..3		+KGM	
6314	Measurement value	C an..18		:3851'	

Description:

Example:

Ideal Message Switzerland

IFTSTA 4.1.0

Segments Layout

Group	SG4	Status:R	Max. occ.: 99999	CNI-SG5
Group	SG5	Status:R	Max. occ.: 99	STS-RFF-DTM-SG8-SG12
Group	SG12	Status:C	Max. occ.: 99	GID-SG13-SG14
Group	SG14	Status:C	Max. occ.: 99	DIM
Segment	DIM	No.: 14 Status:M	Level: 4 Max. occ.: 1	Dimensions

Description Dimensions

Description of Segment:

	Description	St Format	*	Example	Remarks
6145	Dimension type code qualifier	M an..3	*	+1	
C211	Dimensions	M			
6411	Measurement unit code	M an..3		+04'	

Description:

Example:

Ideal-Message Switzerland

IFTSTA 4.1.0

List of changes

No.	Description	Segments and elements	
01	01.07.2016/4.0: Publication of Version 4.0 final	1	UNH

GS1 Switzerland – The Global Language of Business

Global Standards provide more efficiency in value networks. GS1 Switzerland supports companies in optimizing their flows of goods, information and values and provides practical knowledge. Together with our members, we develop standards and process recommendations and create benefits for all parties involved. GS1 Switzerland is a neutral association based in Bern and part of the not-for-profit organization GS1, which is active in 140 countries.

GS1 Switzerland

Monbijoustrasse 68
CH-3007 Bern
T +41 58 800 70 00

www.gs1.ch

